

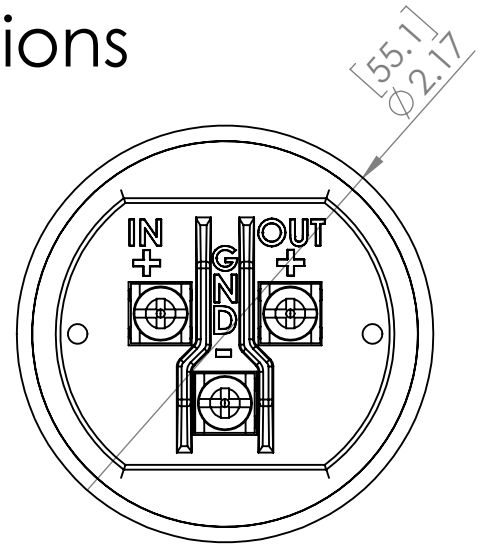

# GasMinder

## Physical Specifications

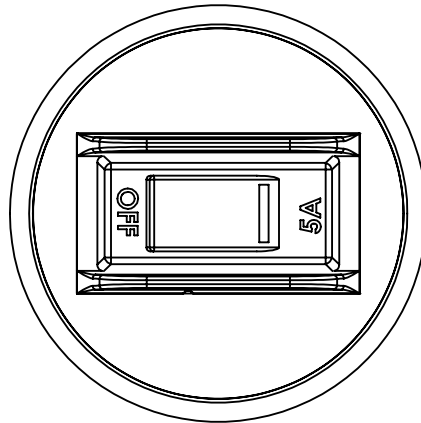
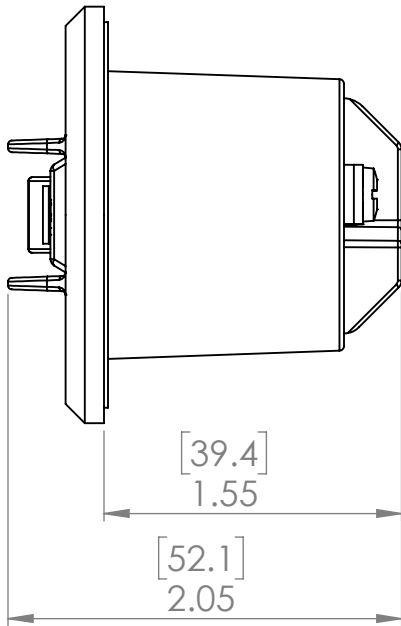

Panel Thickness Guide for Rear-Mount

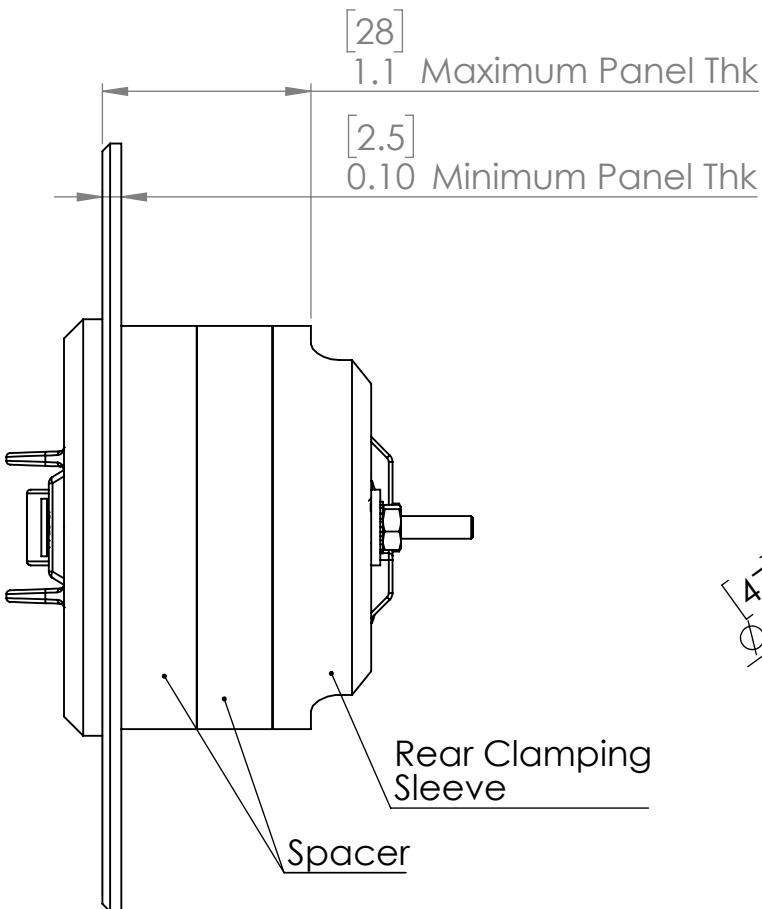

Perimeter and Screw Pattern for Front-Mount Bezel

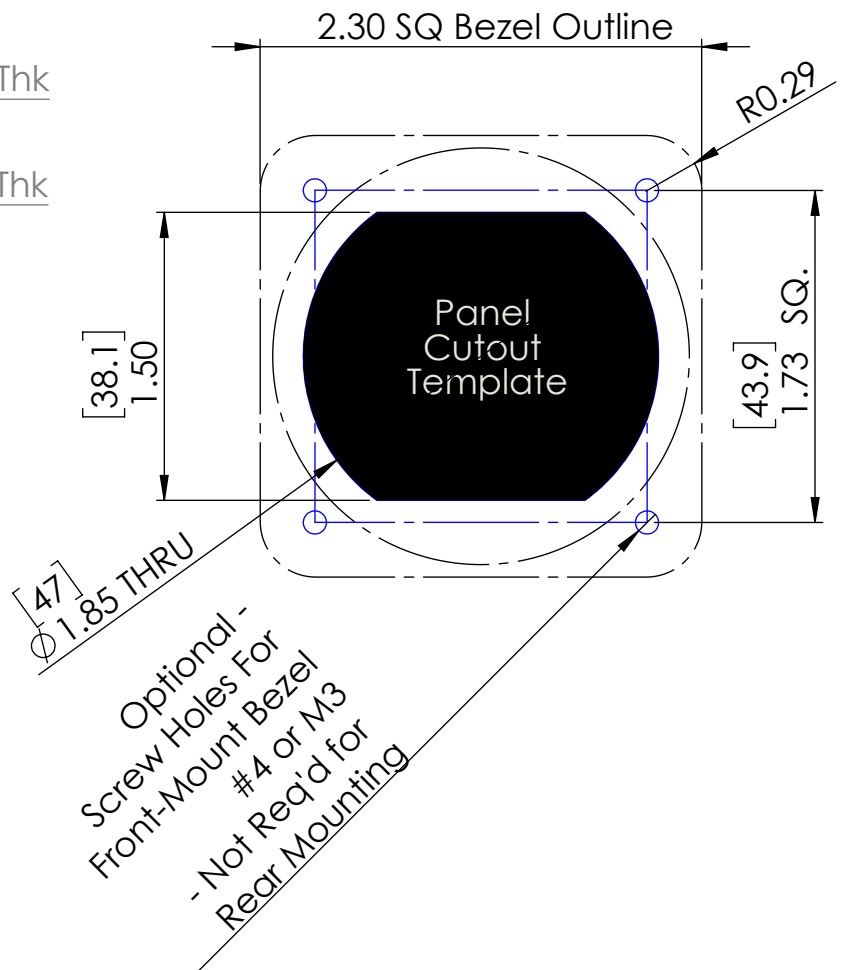



# GasMinder V4 Electrical Specifications

## Features:

- 20-minute Beep-Beep reminder
- Pulsing amber-illuminated PROPANE
- 12/24VDC Marine Systems
- Draws only 13mA when ON
- Thermal Circuit Breaker/Power Switch
  - Rocker-actuated
  - UL Approved
  - 5A
- #6 Terminal Screws
- Choice of mounting scheme

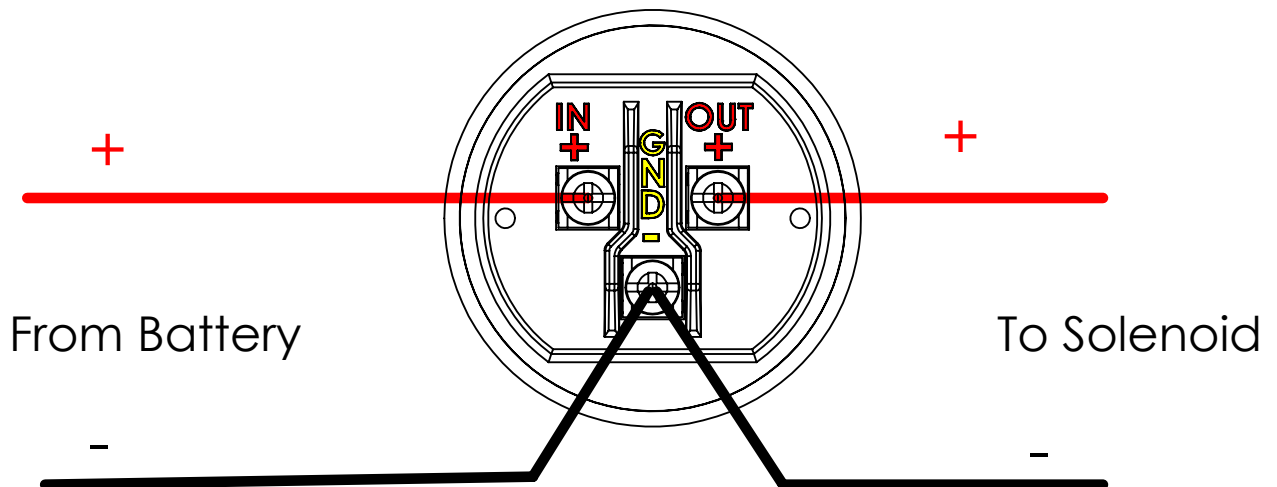



# GasMinder Mounting Options

-Every GasMinder is Supplied with One Mounting Option  
Front OR Rear mount

Front-Mount Kit includes:

- Mounting Bezel, Polycarbonate (1X)
- Gasket (1X)
- Mounting Screws, #4 or M3, SS (4X)

## Front-Mounting Bezel

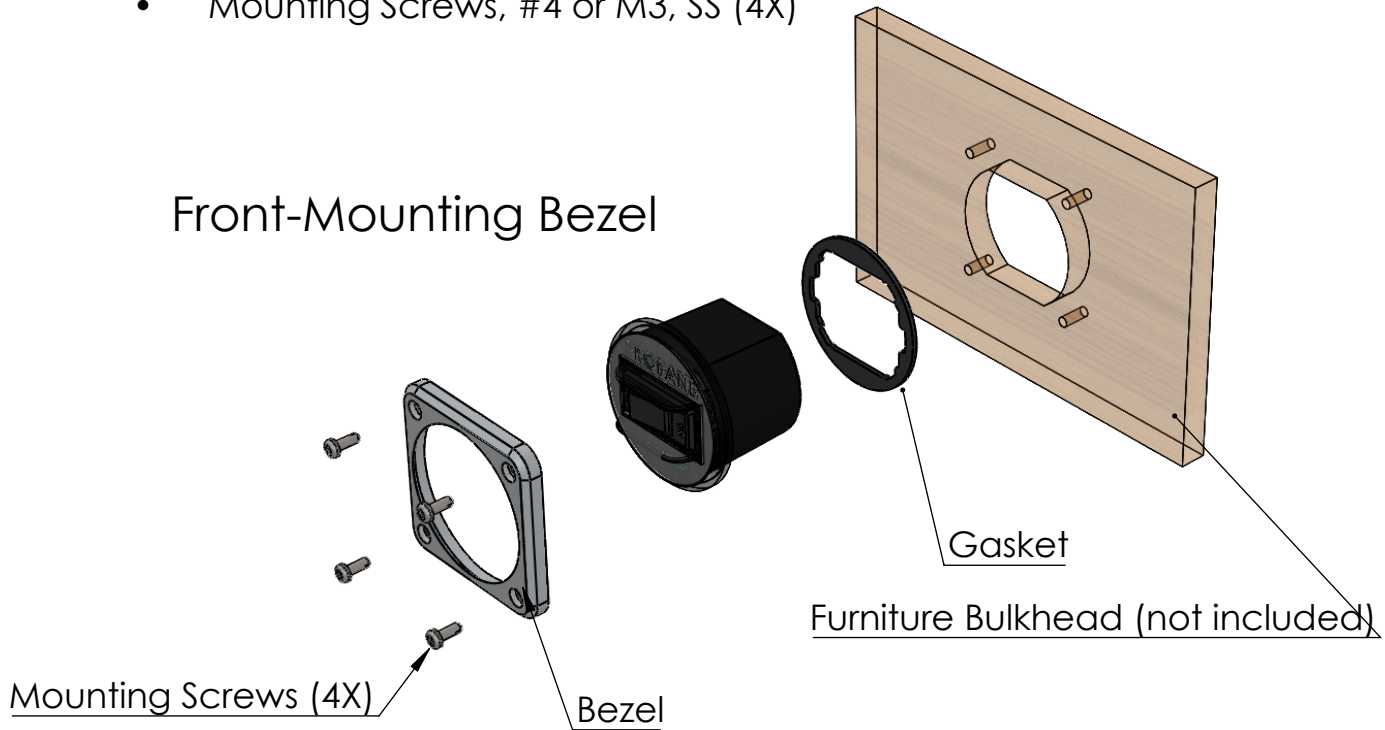

Rear-Mount Kit includes:

- Clamping Sleeve (1X)
- Spacer, 10mm (2X)
- Gasket (1X)
- Fasteners (M3, SS)
  - SS studs (2X)
  - Flat Washers (2X)
  - Lock Washers (2X)
  - Nuts (2X)

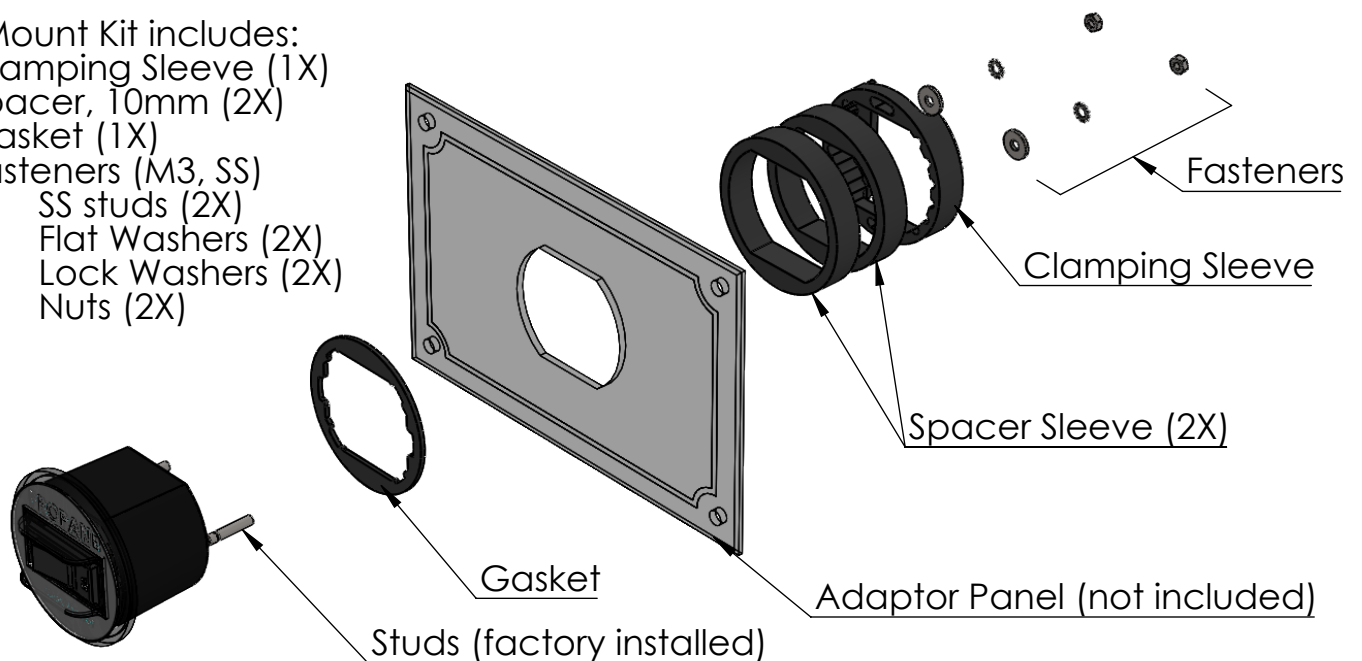

## Rear-Mount Clamping Sleeve